



GroundControl™ Bad Boy HP Luminaire

The GC Bad Boy® Luminaire from PRG is an elegantly engineered luminaire optimized for followspot work.

Producing a powerful 55,000+ lumens, the GC Bad Boy couples its high-definition optics with a Philips MSR Gold™ FastFit lamp that can be set to 1,200W, 1,400W, or 1,630W.

The GC Bad Boy features a full CMY color mixing system and two color correction wheels, one loaded with CTO filters and the other with CTB filters. Colors are servo motor controlled allowing for hyper fast color changes.

The unit contains a mechanical iris which provides continuous beam size control for both rapid changes and smooth timed beam angle changes. Full edge control and variable frost is provided to soften edges. The zoom optics system provides an 8:1 zoom range from narrow spot of 7° to wide flood of 56°. An additional Ultra-Narrow mode changes the zoom range to 4°-10°. The unit is capable of full-field dimming from 0 to 100% with accurate slow-speed control and fast bumps. The unit also contains a servo-powered strobe mechanism for lightning fast strobe effects.

Built-In HD Camera

A High Definition camera is mounted on the fixture that outputs HD-SDI at 1080p enabling the spot operator on the ground to see the stage as if he or she was sitting right next to the fixture. The onboard camera has an optical zoom, targeting reticle, and a night vision mode that enables operators to pick up a performer on a virtually black stage.



Features

SOURCE:	Philips MSR Gold™ 1500W FastFit Lamp. Can be set to 1,200W, 1,400W or 1,630W
OUTPUT:	55,000+ lumens
POWER DRAW:	12.5A at 208V, 10.5A at 240V. Auto-sensing voltage input range is 170V-270V 50/60HZ. Power factor >0.95
REFLECTOR:	Precision glass reflector with dichroic cold mirror coating.
INTENSITY:	Full-field dimming from 0 to 100% with accurate slow-speed control and fast bumps.
STROBE:	Servo-powered, lightning fast strobe.
ZOOM RANGE:	Standard Mode: 8:1 from narrow spot of 7° to wide flood of 56° Ultra Narrow Mode: 4°-10°.
EDGE CONTROL:	Four (4) groups of lenses — each independently controlled for accuracy while maintaining focus during zoom changes
BEAM SIZE IRIS:	A mechanical iris provides continuous beam size control for both rapid changes and smooth timed beam angle changes.
FROST:	Variable frost for smooth diffusion.
COLOR MIXING:	CMY cross fading color mixing system.
COLOR CORRECTION:	Two (2) color correction wheels with seven (7) discrete user-changeable Minus Green, CTO and CTB filters.
ROTATING GOBO:	One (1) indexable, rotating gobo wheel with seven (7) gobos. Gobos are individually calibrated so the unit will automatically index the orientation of each gobo regardless of placement.
OPERATING TEMP:	32° to 120°F (0° to 49°C)
CONTROL:	Compatible with a wide variety of DMX512-A, Art-Net, and sACN consoles.
ON-BOARD CONTROL:	Built-in LCD display with touchscreen menu system. On-board battery power allows for the fixture address and configurations to be set without having to apply AC power to the luminaire
PAN & TILT RANGE:	Pan - 540°, Tilt - 270°
DMX:	37 Channels

GroundControl™ Bad Boy Luminaire Specifications

Dimensions

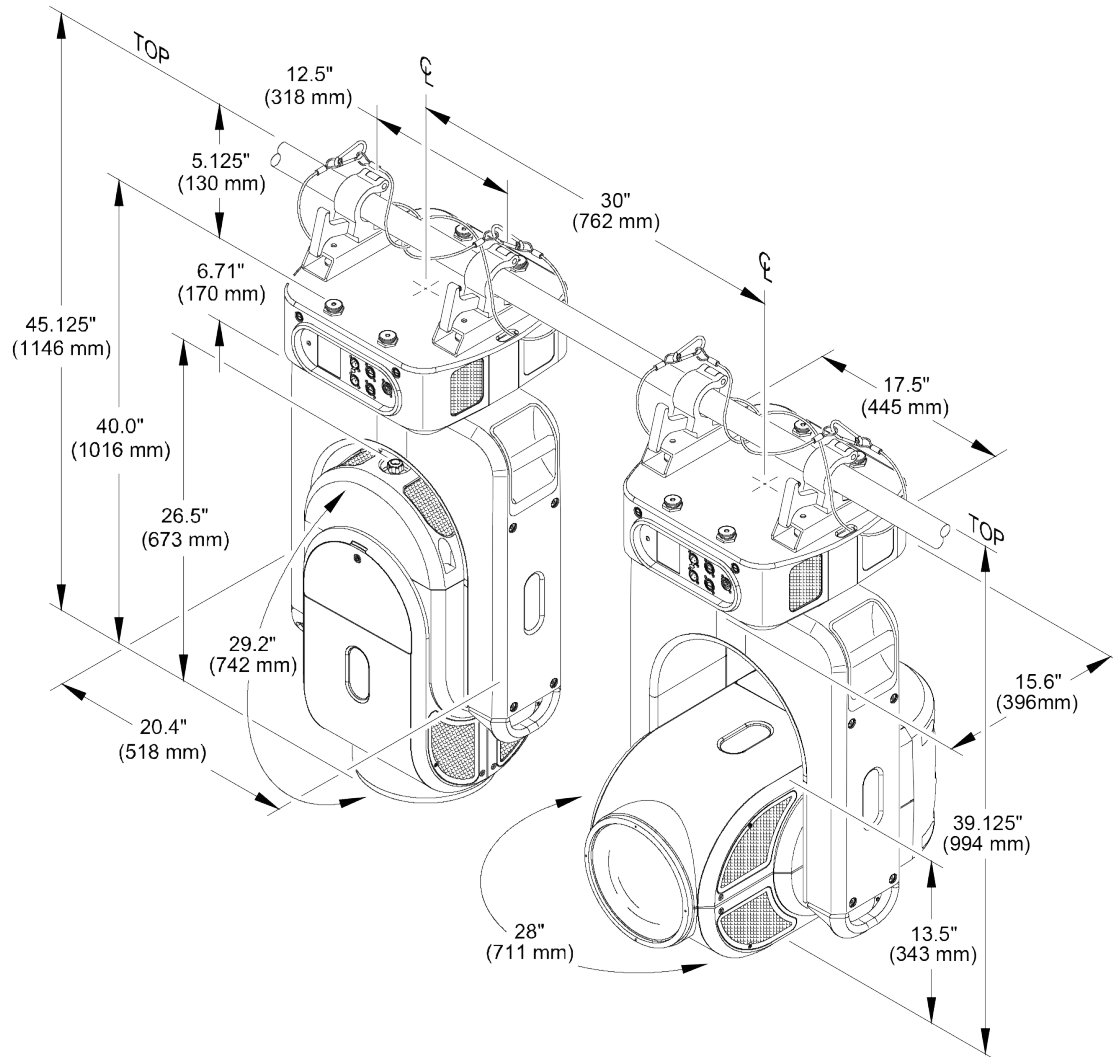
**POSITIONING:**

Can be mounted in any orientation.

SPACING:

Hangs on 30 inch (762 mm) centers.

WEIGHT:

171 lbs (77 Kg) without hooks

BAD BOY® IS A REGISTERED TRADEMARK OF PRODUCTION RESOURCE GROUP, LLC.